

VÁLVULA DE ESFERA 2 CUERPOS INOXIDABLE CON BRIDAS 2 PIECES STAINLESS STEEL BALL VALVE FLANGED

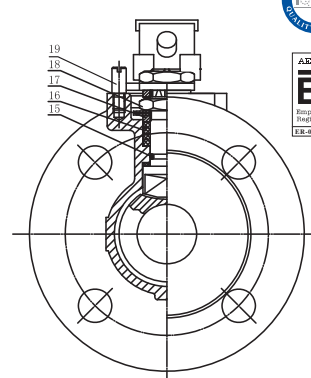
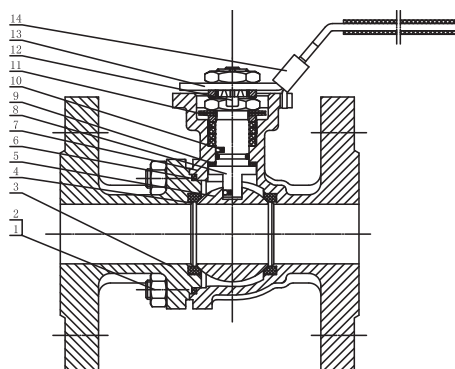
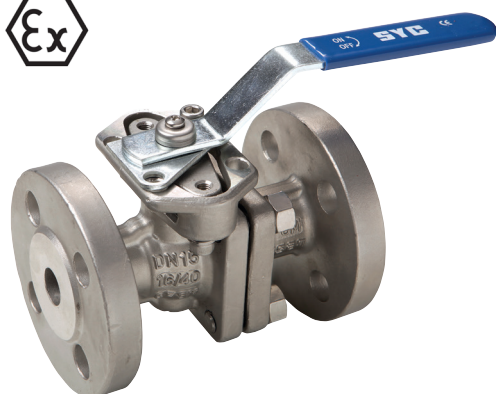

DESCRIPCIÓN COMPONENTES - COMPONENTS DESCRIPTION

Ítem	Descripción - Description	Material - Material
1	Perno - Stud	A193 - B8
2	Tuerca - Nut	A194 - 8
3	Tapón - Cap	A351 CF8M
4	Asiento - Seat	PTFE + 15% FV/GF
5	Bola - Ball	SS316
6	Junta - Gasket	PTFE
7	Eje - Stem	A276 316
8	Cuerpo - Body	A351 CF8M
9	Junta del eje - Stem Gasket	PTFE
10	Dispositivo antiestático - Antistatic Device	A276 304
11	Muelle mariposa - Butterfly Spring	A276 304
12	Tapón antipérdida - Anti Loosing Cap	A276 304
13	Maneta - Handle	A276 201
14	Seguro - Handle Lock	A276 201
15	O-ring	Viton
16	Junta - Gasket	PTFE
17	Anilla - Packing Gland	A276 304
18	Tuerca del eje - Stem Nut	A194 - 8
19	Sistema frenado - Stop Pin	A276 304

CARACTERÍSTICAS BÁSICAS

- Construcción en acero inoxidable CF8M.
- Presión máxima de ejercicio: PN 40 de DN 15 a DN 40 ; PN 16 de DN 50 a DN 150.
- Temperatura de servicio: -30 °C a 150 °C.
- Bridas DIN 2635 PN 40 de DN 15 a DN 40; DIN 2633 PN 16 de DN 50 a DN 150.
- Seguridad contra incendios API 607.
- Longitud entre caras según DIN 3202-F4.
- Dispositivo anti-estático.
- Montaje actuador directo según ISO 5211.
- Certificado ATEX según la Directiva 2014/34/EU.

APLICACIONES GENERALES

- Productos químicos.
- Industrias petroquímicas.
- Aplicaciones industriales.
- Sistemas de calefacción.
- Instalaciones hidráulicas.
- Aire comprimido.

BASIC FEATURES

- Made in stainless steel CF8M.
- Maximum working pressure: PN 40 from DN 15 to DN 40; PN 16 from DN 50 to DN 150.
- Working temperature: -30 °C to 150 °C.
- Flanges DIN 2635 PN 40 from DN 15 to DN 40; DIN 2633 from DN 50 to DN 150.
- Fire safe API 607.
- Length face to face according to DIN 3202-F4.
- Anti-static device.
- Direct mounting for actuators ISO 5211.
- ATEX certificate in accordance with Directive 2014/34/EU.

GENERAL APPLICATIONS

- Chemical industries.
- Petrochemical industries.
- Industrial applications.
- Heating systems.
- Hydraulic installation.
- Compressed air.

Rev.2-02.20
1/3

VÁLVULA DE ESFERA 2 CUERPOS INOXIDABLE CON BRIDAS 2 PIECES STAINLESS STEEL BALL VALVE FLANGED

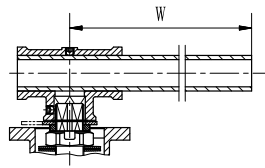

DN125

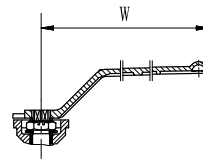

DN65~DN100

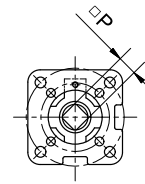

ISO 5211

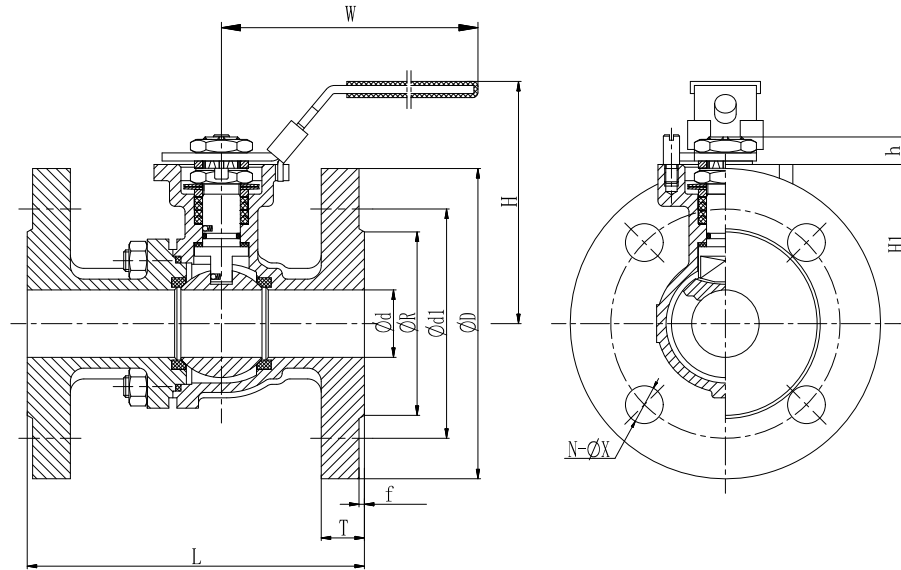

INFORMACIÓN TÉCNICA - TECHNICAL INFORMATION

DN	COD.	Ød (mm)	ØR (mm)	Ød1 (mm)	ØD (mm)	H1 (mm)	H (mm)	h (mm)	L (mm)	W (mm)	T (mm)	f (mm)	Taladros Bolting N - Ø (mm)	□P (mm)	ISO 5211	Peso aprox. Weight aprox. (kg)
15	IVB20015	15	45	65	95	48,5	76	8,5	115	110	14	2	4 - ø14	9	F03-F04	2,20
20	IVB20020	20	58	75	105	53,5	81	8,5	120	110	16	2	4 - ø14	9	F03-F04	3,05
25	IVB20025	25	68	85	115	59	90	10	125	140	16	2	4 - ø14	11	F04-F05	3,75
32	IVB20032	32	78	100	140	71	102	10	130	140	16	2	4 - ø18	11	F04-F05	5,75
40	IVB20040	38	88	110	150	77,5	114,5	14	140	185	16	3	4 - ø18	14	F05-F07	7,00
50	IVB20050	50	102	125	165	85	122	14	150	185	18	3	4 - ø18	14	F05-F07	9,50
65	IVB20B65	65	122	145	185	100	168	16	170	305	18	3	4 - ø18	17	F07-F10	14,75
80	IVB20080	78	138	160	200	110	178	16	180	305	20	3	8 - ø18	17	F07-F10	18,85
100	IVB20100	100	158	180	220	130	198	18	190	305	20	3	8 - ø18	19	F07-F10	26,25
125	IVB20125	125	188	210	250	165	234	23	325	500	22	3	8 - ø18	22	F10-F12	38,00
150	IVB20150	150	212	240	285	190	250	28	350	645	22	3	8 - ø22	27	F12-F14	51,00

Observaciones:

Dada la complejidad, variedad y gran cantidad de especificaciones particulares de cada instalación, en conjunción con la existencia de diversos factores que pueden afectar a las condiciones de trabajo y naturaleza del producto, es responsabilidad del usuario final realizar los ensayos necesarios para garantizar el correcto funcionamiento del producto en cada aplicación concreta. La instalación del producto deberá realizarse y mantenerse siguiendo códigos de buena práctica y/o estándares existentes.

Remarks:

Due to the complexity, variety and large number of particular specifications for each installation, along with the existence of diverse factors which can affect the working conditions and nature of the product, it is the responsibility of the end-user to carry out the necessary tests to ensure the proper functioning of the product in any specific application. Product installation must be carried out and maintained following the good practice codes and/or updated technical standards.

Rev.2-02.20
2/3

VÁLVULA DE ESFERA 2 CUERPOS INOXIDABLE CON BRIDAS 2 PIECES STAINLESS STEEL BALL VALVE FLANGED



DIAGRAMA PÉRDIDAS DE CARGA / HEAD LOSS CHART

(Agua en flujo horizontal a 20 °C / Water in horizontal flow at 20 °C)

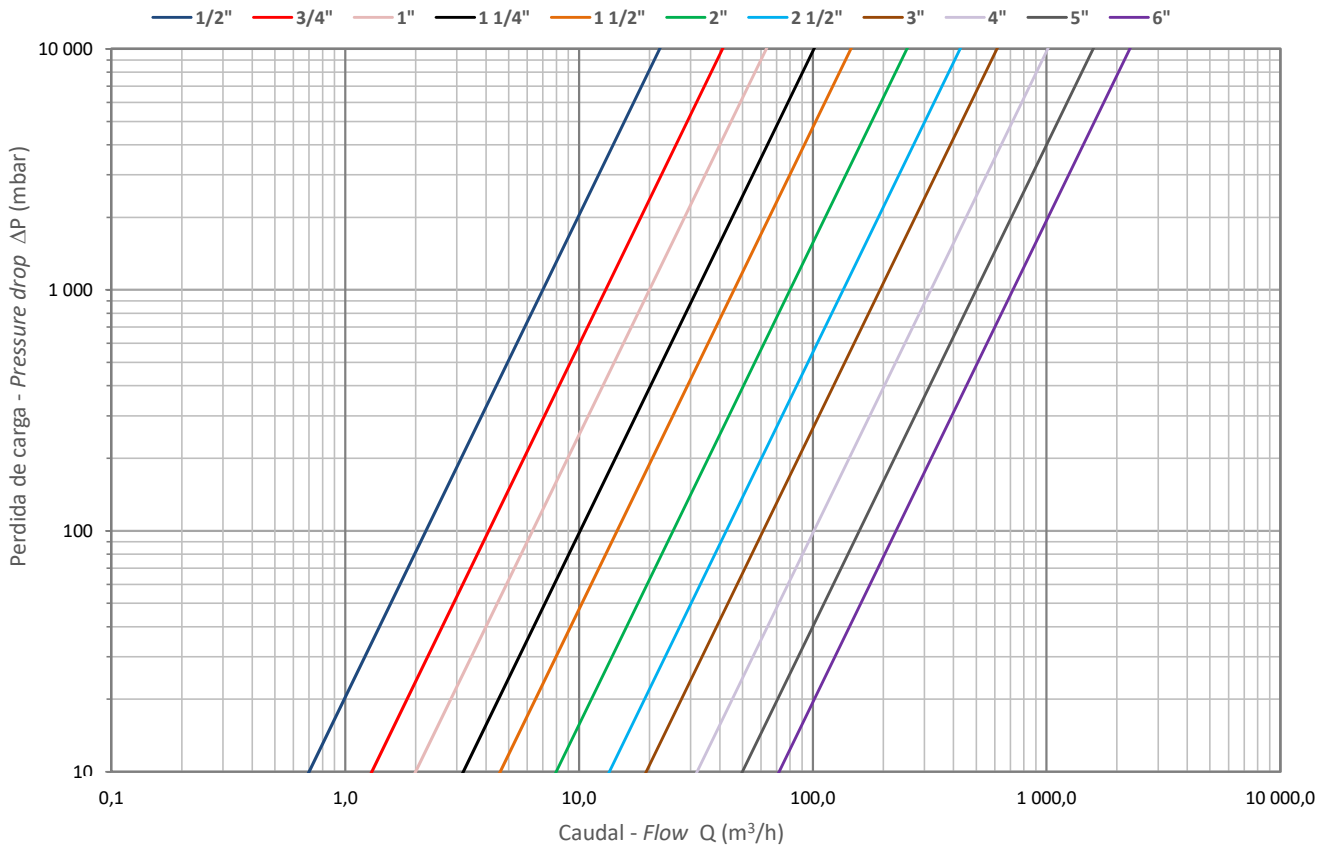

Nota: 1 mca = 100 mbar

Medida - Size (inches)	1/2"	3/4"	1"	1 1/4"	1 1/2"	2"	2 1/2"	3"	4"	5"	6"
Diámetro nominal - Nominal size	DN 15	DN 20	DN 25	DN 32	DN 40	DN 50	DN 65	DN 80	DN 100	DN 125	DN 150
Coefficiente de caudal - Flow coefficient	Kv 7	Kv 13	Kv 20	Kv 32	Kv 46	Kv 80	Kv 135	Kv 194	Kv 320	Kv 500	Kv 718

Kv : coeficiente que expresa el caudal circulante (expresado en m³/h) a través de la valvula generando una caída de presión a su paso de 1 bar (1000 mbar)

Kv: is the rate of flow (in cubic metres per hour) at a pressure drop of 1 bar (1000 mbar) through the valve

DIAGRAMA PRESIÓN - TEMPERATURA / PRESSURE - TEMPERATURE DIAGRAM

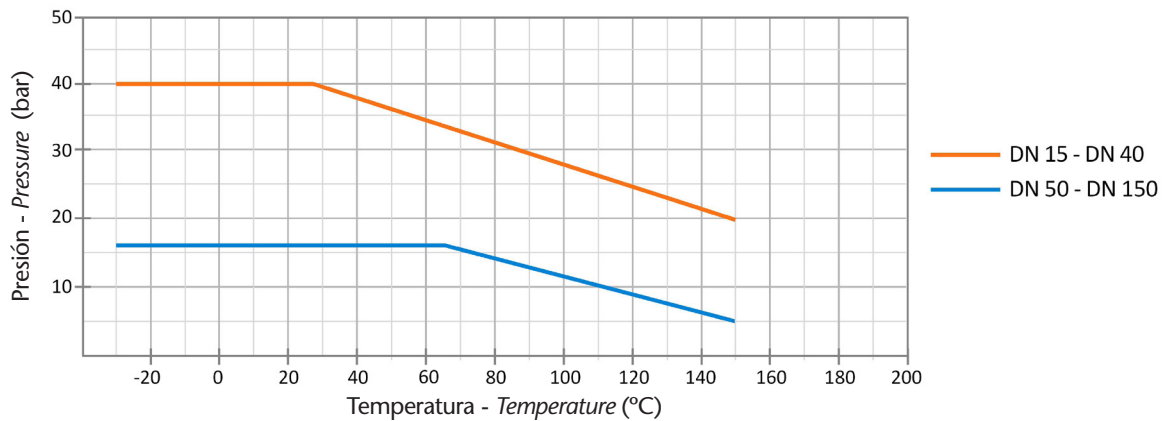

Nota : Debido al constante desarrollo de nuestros productos, los datos suministrados pueden ser alterados sin previo aviso.

Note : Due to the continuous development of our products, specifications may be changed without notification at any time.

Rev.2-02.20

3/3



Polígono Industrial ATUSA - Agurain S/N - 01200 Salvatierra (Alava) España
Tel.: (+34) 945 18 00 00 Fax : (+34) 945 30 01 53 e-mail: ventas@atusa.es
www.atusa.es

