

ACTUADORES NEUMATICOS DE SIMPLE Y DOBLE EFECTO

SINGLE RETURN AND DOUBLE ACTING PNEUMATIC ACTUATORS



DESCRIPCIÓN DEL PRODUCTO

Actuador neumático rotativo con sistema "cremallera-piñón" que transforma la energía del aire comprimido en energía mecánica de rotación limitada a un giro de cuarto de vuelta (90°) idóneo para la automatización de cualquier tipo de válvula con giro de 90° (bola, mariposa, etc) garantizando un alto número de ciclos.

La instalación del actuador neumático permite operar una válvula sin la intervención manual de un operador a través de dispositivos de control colocados en remoto.

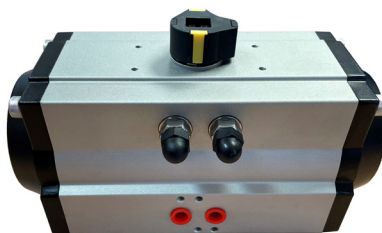

PRODUCT DESCRIPTION

Rotary pneumatic actuator with "rack-pinion" system that transforms the energy of the compressed air into mechanical energy of rotation limited to a quarter turn (90°), suitable for the automation of any type of valve with a 90° turn (ball, butterfly, etc) guaranteeing a high number of cycles.

The installation of the pneumatic actuator allows to operate a valve without manual intervention of an operator through control devices placed remotely.



DESIGNACION

- Simple efecto: ida por aire y retorno por muelles (SE).
- Doble efecto: ida y retorno por aire (DE).
- Número de serie grabado en todos los cuerpos.

CARACTERISTICAS GENERALES

- Doble taladrado inferior para el anclaje y centraje de la válvula según ISO 5211/DIN 3337.
- Ajuste externo del recorrido angular de los pistones ($\pm 5^\circ$) tanto en apertura como en cierre.
- Indicador de posición incorporado.
- Equipados de serie con 12 muelles (solo simple efecto).
- Eje no eyectable.
- Temperatura para construcción estándar: -20°C a 80°C .
- Protección ingreso IP67.
- Homologación ATEX según Directiva 2014/34/UE.

Nota 1: Eliminando o añadiendo los muelles necesarios su diseño permite intercambiar la configuración de SE a DE y viceversa.

Nota 2: El actuador se suministra para rotación en sentido anti-horario.

CARACTERISTICAS OPCIONALES

- Cambio de sentido de giro.
- Pilotaje neumático (montaje directo de electroválvulas tipo 5/2, 3/2 y biestables 5/2 y de accesorios NAMUR VDI/VDE3845).
- Finales de carrera electromecánicos SPDT y ATEX.
- Posicionadores neumáticos, electropneumáticos y electropneumáticos digitales.
- Reductor manual desmontable.
- Complementos varios (silenciador, regulación escape, placa adaptadora control velocidad).

APLICACIONES GENERALES

- Suministro de aguas y riego.
- Obra hidráulica y civil compatibles.
- Procesos diversos (alimentación, farmacia, industria variada).
- Climatización.

Observaciones:

Dada la complejidad, variedad y gran cantidad de especificaciones particulares de cada instalación, en conjunción con la existencia de diversos factores que pueden afectar a las condiciones de trabajo y naturaleza del producto, es responsabilidad del usuario final realizar los ensayos necesarios para garantizar el correcto funcionamiento del producto en cada aplicación concreta. La instalación del producto deberá realizarse y mantenerse siguiendo códigos de buena práctica y/o estándares existentes.

DESIGNATION

- Single Return: go by air and return by springs (SR).
- Double Acting: go and return by air (DA).
- Serial number engraved on all bodies.

GENERAL CHARACTERISTICS

- Double drilled hole for anchoring and centering the valve according to ISO 5211 / DIN 3337.
- External adjustment of the angular running of the pistons ($\pm 5^\circ$) both in opening and closing.
- Built-in position indicator.
- Standard equipped with 12 springs (single acting only).
- Non-ejectable shaft.
- Temperature for standard construction: -20°C to 80°C . Ingress protection IP67.
- ATEX approval according to Directive 2014/34/EU.

Note 1: By eliminating or adding the necessary springs, its design allows to exchange the configuration from SR to DA and back.

Note 2: The actuator is supplied for counter-clockwise rotation (CCW).

OPTIONAL CHARACTERISTICS

- Change of direction of rotation.
- Pneumatic control (direct mounting of NAMUR VDI/VDE3845 accessories and solenoid valves type 5/2, 3/2 and 5/2 bi stable).
- Electromechanical limit switches SPDT and ATEX.
- Pneumatic, electropneumatic and digital electropneumatic positioners.
- Detachable manual gearbox.
- Various accessories (muffler, exhaust regulation, speed control adapter plate).

GENERAL APPLICATIONS

- Water supply and irrigation.
- Compatible hydraulic and civil works.
- Various processes (food, pharmacy, various industry).
- Air conditioning.

Remarks:

Due to the complexity, variety and large number of particular specifications for each installation, along with the existence of diverse factors which can affect the working conditions and nature of the product, it is the responsibility of the end-user to carry out the necessary tests to ensure the proper functioning of the product in any specific application. Product installation must be carried out and maintained following the good practice codes and/or updated technical standards.

Rev.0-07.21

1/11

ACTUADORES NEUMATICOS DE SIMPLE Y DOBLE EFECTO

SINGLE RETURN AND DOUBLE ACTING PNEUMATIC ACTUATORS



INSTALACIÓN

- Para la utilización de los actuadores, además de las características de serie de los mismos, deberán ser tenidos en cuenta la naturaleza del fluido, las condiciones medioambientales y las características de las válvulas a actuar.
- Los fluidos a conducir deberán estar en estado líquido y exentos de materiales que les confieran carácter de incrustantes y/o agresivos estando además libres de contaminantes que puedan modificar la fricción del sistema de apertura-cierre de las válvulas por resecaamiento o cualquier otra causa.
- Adicionalmente, la velocidad del fluido deberá ser estable y deberá disponerse de un protocolo que garantice un ciclo de operación (apertura-cierre mínimo) definido.
- Para cualquier otro tipo de fluido, ya sea líquido, gaseoso o pulverulento, debe realizarse consulta previa antes del pedido.
- La geometría y características que definen los torques de las válvulas deberán ser compatibles con las propiedades estándar de los actuadores con los que se actúen debiendo ser éstas debidamente ensambladas con los elementos previstos y conectadas al fluido de alimentación neumático y/o eléctrico por personal competente.
- ATUSA no se hace responsable de la actuación de válvulas no suministradas por ella.

INSTALLATION

- In order to use the actuators, in addition to their standard characteristics, the nature of the fluid, the environmental conditions and the characteristics of the valves to be operated must be taken into account.
- The fluids to be conducted must be liquids and free of materials that make them encrusting and / or aggressive, being also free of contaminants that can modify the friction of the valve opening-closing system due to drying out or any other cause.
- Additionally, the speed of the fluid must be stable and a protocol must be available that guarantees a defined operating cycle (minimum opening-closing).
- For any other type of fluid, whether liquid, gaseous or powdery, prior consultation must be made before ordering.
- The geometry and characteristics that define the torques of the valves must be compatible with the standard properties of the actuators which they are operated, and valves must be properly assembled with the elements planned and connected to the pneumatic and / or electrical supply fluid by competent personnel.
- ATUSA is not responsible for the actuation of valves not supplied by itself.

CONSTRUCCION

CONSTRUCTION

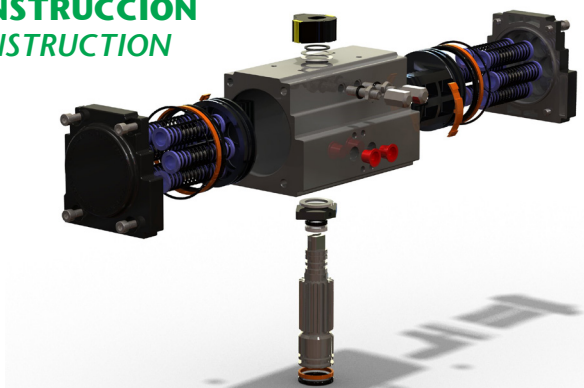

Esquema Actuator Simple Efecto y Doble Efecto (sin muelles)
Scheme Actuator Single Return and Double Acting (without springs)

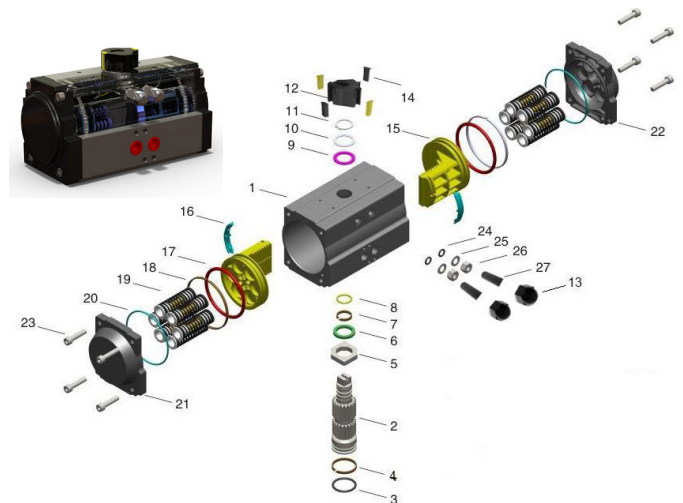

DESCRIPCIÓN DE COMPONENTES - COMPONENTS DESCRIPTION

Ítem	Piezas - Parts	Descripción - Description	Material - Material
1	1	Cuerpo - Body	Aleación Al. extruido - Aluminium alloy
2	1	Eje/piñón - Shaft/pinion	Acero+Ni - Carbon steel+Ni
3	1	Junta inferior piñón - O-ring pinion bottom	NBR
4	1	Anillo antifricción - Bearing	Nylon 46
5	1	Leva - Cam	Acero inox - Stainless steel
6	1	Anillo superior antifricción - Bearing (Pinion Top)	Nylon 46
7	1	Anillo antifricción salida eje - O-ring (Pinion Top)	Nylon 46
8	1	Junta superior eje - O-ring (Pinion top)	NBR
9	1	Anillo antifricción - Bearing	Nylon 46
10	1	Arandela superior - Washer (Pinion top)	Acero Inox - Stainless steel
11	1	Circlip - Spring clip	Acero Inox - Stainless steel
12	1	Indicador posición - Position Indicator	PP+30%GF
13	2	Tuerca ciega torn. ajuste - Acorn nut adj. bolt	Nylon
14	4	Barra indicador posición - Position indicator bar	PP+30%GF
15	2	Pistón - Piston	Aleación Al. - Aluminium alloy
16	2	Patín antifricción - Guide	Nylon 46
17	2	Junta pistón - O-ring piston	NBR
18	2	Anillo antifricción pistón - Bearing (piston)	Compuesto fluor-carbon - Fluorine-carbon composite
19	5-12	Muelles precomprimidos - Spring cartridge	Acero - Carbon Steel
20	2	Junta tapa - End cap O-ring	NBR
21	1	Tapa izquierda - Left end cap	Aleación Aluminio - Aluminium alloy
22	1	Tapa derecha - Right end cap	Aleación Aluminio - Aluminium alloy
23	8	Tornillo tapa - End cap screw	Acero inox - Stainless steel
24	2	Junta tornillo ajuste - Adjust screw O-ring	NBR
25	2	Arandela tornillo ajuste - Adjust screw washer	Acero inox - Stainless steel
26	2	Tuerca fijación tornillo - Adjust screw nut	Acero inox - Stainless steel
27	2	Tornillo ajuste - Adjust screw	Acero inox - Stainless steel

Rev.0-07.21
2/11



Polígono Industrial ATUSA - Agurain S/N - 01200 Salvatierra (Alava) España
Tel.: (+34) 945 18 00 00 Fax : (+34) 945 30 01 53 e-mail: ventas@atusa.es
www.atusa.es





ELEMENTOS BÁSICOS

- Cuerpo: aleación de aluminio extruido con protección anticorrosiva de anodizado duro.
- Pistones: aleación de aluminio inyectado, anodizados y mecanizados para prolongar la vida del actuador.
- Tapas de protección externa: aluminio inyectado con recubrimiento epóxi-poliéster.
- Patines: nylon (deslizantes con bajo coeficiente de fricción para evitar contacto metal-metal).
- Piñón: acero al carbono niquelado.
- Resortes: acero recubierto de resina epoxy.
- Juntas de estanqueidad: NBR (VITON o EPDM bajo pedido).
- Tornillería: acero inoxidable AISI 304.

CURVAS TÍPICAS DE ACTUACION

- **Doble efecto:** para una presión de alimentación dada el actuador ofrece un par constante en toda la carrera. Este par debe ser superior al par de la válvula¹⁾ que se desea actuar.
- **Simple efecto:** para una presión de alimentación dada el actuador ofrece cuatro pares extremos diferentes. Desde la posición de suministro por defecto (NC - Normalmente Cerrado), cuando se presuriza hace el giro anti-horario (0° a 90°) ofreciendo el aire dos pares límite, uno en cada final de carrera. Cuando se elimina/descarga la presión del aire el muelle hace el giro (90° a 0°) horario devolviendo su energía acumulada ofreciendo respectivamente dos pares. Estos pares²⁾ deben ser superiores en ambas carreras a las curvas de par de la válvula¹⁾ que se desea actuar.

¹⁾ Se requiere conocer el par máximo de la válvula el cual debe ser adicionalmente multiplicado por un factor de seguridad (25-30%). Este factor de seguridad puede ser mayor dependiendo de las condiciones del fluido y la instalación.

²⁾ En simple efecto, debe prestarse especial atención al par de cierre del muelle (el par a 0°).

BASIC COMPONENTS

- Body: extruded aluminum alloy with hard anodizing corrosion protection.
- Pistons: Injected aluminum alloy, anodized and machined to prolong the life of the actuator.
- External protection caps: injected aluminum with epoxy-polyester coating.
- Guides: nylon (sliding with low friction coefficient to avoid metal-metal contact).
- Pinion: nickel plated carbon steel.
- Springs: epoxy resin coated steel.
- Seals: NBR (VITON or EPDM on request).
- Screws: AISI 304 stainless steel.

TYPICAL ACTUATION CURVES

- **Double acting:** for a given supply pressure the actuator offers a constant torque over the entire stroke. This torque must be higher than the torque of the valve¹⁾ to be operated.
- **Single acting:** for a given supply pressure the actuator offers four different extreme torques. From the default supply position (NC-Normally Closed), when pressurized, the actuator makes counter-clockwise (0° to 90°), offering the air two limit torques, one at each limit stroke. When the air pressure is eliminated/discharged, the spring makes a clockwise turn (90° to 0°), returning its accumulated energy, and therefore offering two pairs. These torques²⁾ must be greater in both strokes than the torque curves of the valve¹⁾ to be operated.

¹⁾ It is required to know the maximum torque of the valve which must be additionally increased by a safety factor of 25-30%. This safety factor may be higher depending on the fluid and installation conditions.

²⁾ In simple effect, special attention must be taken to the closing torque of the spring (the torque at 0°).

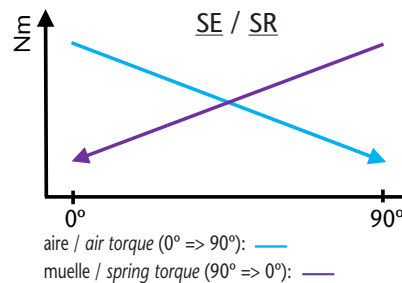
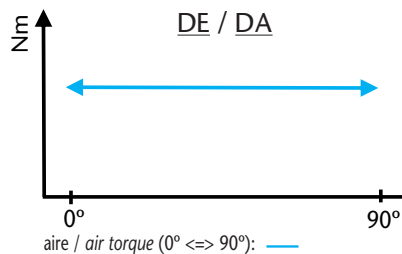

PARES CARACTERISTICOS PARA APLICACIONES ESTÁNDAR

- Alimentación con aire comprimido filtrado, seco o lubricado. Presión mínima de 2 bar (DE) / 3 bar (SE) y máxima de 8 bar (SE y DE). Los pares ofrecidos son para aplicaciones estándar.

CHARACTERISTIC TORQUES FOR STANDARD APPLICATIONS

- Supply with filtered, dry or lubricated compressed air. Minimum pressure of 2 bar for DA / 3 bar for SE and maximum of 8 bar for SR and DA. Torques offered are for standard applications

PARES ACTUADORES DOBLE EFECTO / DOUBLE ACTING TORQUE RATINGS

Modelo - Model	TORQUES SUMINISTRADOS (Nm) - SUPPLIED TORQUES (Nm)						
	Alimentación presión de aire - Air pressure supply						
	2 bar	3 bar	4 bar	5 bar	6 bar	7 bar	8 bar
ACDE0052	8,5	12,7	17,0	21,2	25,5	29,7	34,0
ACDE0063	15,0	22,5	30,0	37,5	44,9	52,4	59,9
ACDE0075	24,7	37,1	49,5	61,9	74,2	86,6	99,0
ACDE0083	32,5	48,7	65,0	81,2	97,4	113,7	130,0
ACDE0092	46,5	69,8	93,0	116,3	140,0	162,9	186,0
ACDE0105	69,3	104,0	138,5	173,2	207,8	242,5	277,0
ACDE0125	122,7	184,0	245,5	306,8	368,0	429,5	490,8
ACDE0140	184,7	277,0	369,5	461,8	554,0	646,5	739,0
ACDE0160	281,5	422,0	563,0	704,0	844,0	985,0	1 126,0
ACDE0190	453,0	680,0	907,0	1 134,0	1 361,0	1 587,0	1 814,0
ACDE0210	623,0	935,0	1 246,0	1 558,0	1 870,0	2 182,0	2 493,0
ACDE0240	977,0	1 465,0	1 954,0	2 443,0	2 931,0	3 420,0	3 908,0
ACDE0270	1 374,0	2 061,0	2 748,0	3 435,0	4 122,0	4 809,0	5 496,0
ACDE0300	1 696,0	2 544,0	3 392,0	4 241,0	5 089,0	5 937,0	6 785,0

ACTUADORES NEUMATICOS DE SIMPLE Y DOBLE EFECTO SINGLE RETURN AND DOUBLE ACTING PNEUMATIC ACTUATORS



PARES ACTUADORES SIMPLE EFECTO / SINGLE RETURN TORQUE RATINGS

TORQUES SUMINISTRADOS (Nm) - SUPPLIED TORQUES (Nm)

Modelo Model	Muelles Springs	Par de muelles Spring torques		Alimentación presión de aire - Air pressure supply												
		Inicio Begin	Fin End	3 bar		4 bar		5 bar		6 bar		7 bar		8 bar		
				Inicio Begin	Fin End	Inicio Begin	Fin End	Inicio Begin	Fin End	Inicio Begin	Fin End	Inicio Begin	Fin End	Inicio Begin	Fin End	
		90°	0°	0°	90°	0°	90°	0°	90°	0°	90°	0°	90°	0°	90°	
ACSE0052	5	5,4	4,0	8,8	7,3	13,0	11,6									
	6	6,5	4,7	8,0	6,3	12,3	10,5	16,5	14,8							
	7	7,6	5,5	7,2	5,2	11,5	9,4	15,7	13,7	20,0	17,9					
	8	8,6	6,3	6,4	4,1	10,7	8,4	14,9	12,6	19,2	16,8	23,4	21,1			
	9	9,7	7,1			9,9	7,3	14,1	11,5	18,4	15,8	22,6	20,0	26,9	24,3	
	10	10,8	7,9			9,1	6,2	13,3	10,4	17,6	14,7	21,8	18,9	26,1	23,2	
	11	11,9	8,7					12,6	9,4	16,8	13,6	21,0	17,9	25,3	22,1	
	12	13,0	9,5					11,8	8,3	16,0	12,5	20,3	16,8	24,5	21,0	
	ACSE0063	5	9,9	6,8	15,7	12,5	23,2	20,0								
		6	11,9	8,1	14,3	10,5	21,8	18,0	29,3	25,5						
		7	13,9	9,5	13,0	8,5	20,4	16,0	27,9	23,5	35,4	31,0				
		8	15,9	10,9	11,6	6,5	19,1	14,0	26,6	21,5	34,0	29,0	41,5	36,5		
9		17,9	12,2			17,7	12,0	25,2	19,5	32,7	27,0	40,2	34,5	47,7	42,0	
10		19,9	13,6			16,4	10,0	23,9	17,5	31,3	25,0	38,8	32,5	46,3	40,0	
11		21,9	14,9					22,5	15,5	30,0	23,0	37,5	30,5	44,9	38,0	
12		23,9	16,3					21,1	13,6	28,6	21,0	36,1	28,5	43,6	36,0	
ACSE0075		5	15,5	10,2	27,0	21,6	39,3	34,0								
		6	18,6	12,2	24,9	18,6	37,3	30,9	49,7	43,3						
		7	21,7	14,2	22,9	15,5	35,3	27,8	47,6	40,2	60,0	52,6				
		8	24,8	16,2	20,9	12,4	33,2	24,7	45,6	37,1	58,0	49,5	70,4	61,8		
	9	27,9	18,3			31,2	21,6	43,6	34,0	56,0	46,4	68,3	58,7	80,7	71,1	
	10	30,9	20,3			29,2	18,5	41,6	30,9	53,9	43,3	66,3	55,7	78,7	68,0	
	11	34,0	22,3					39,5	27,8	51,9	40,2	64,3	52,6	76,6	64,9	
	12	37,1	24,4					37,5	24,7	49,9	37,1	62,2	49,5	74,6	61,8	
	ACSE0083	5	21,5	14,9	33,9	27,2	50,1	43,4								
		6	25,6	17,8	30,9	22,9	47,1	39,1	63,3	55,3						
		7	30,1	20,8	27,9	18,6	44,1	34,8	60,4	51,0	76,6	67,3				
		8	34,4	23,8	24,9	14,3	41,2	30,5	57,4	46,7	73,6	63,0	89,9	79,2		
9		38,8	26,7			38,2	26,2	54,4	42,4	70,7	58,7	86,9	74,9	103,1	91,1	
10		43,1	29,7			35,2	21,9	51,5	38,1	67,7	54,3	83,9	70,6	100,2	86,8	
11		47,4	32,7					48,5	33,8	64,7	50,0	81,0	66,3	97,2	82,5	
12		51,7	35,6					45,5	29,5	61,8	45,7	78,0	62,0	94,2	78,2	
ACSE0092		5	30,3	21,8	48,0	39,5	71,3	62,8								
		6	35,3	26,2	43,7	33,5	66,9	56,7	90,2	80,0						
		7	42,4	30,5	39,3	27,4	62,6	50,7	85,8	74,0	109,1	97,2				
		8	48,4	34,9	34,9	21,4	58,2	44,6	81,5	67,9	104,7	91,2	128,0	114,4		
	9	54,5	39,2			53,9	38,6	77,1	61,8	100,4	85,1	123,7	108,4	146,9	131,6	
	10	60,6	43,6			49,5	32,5	72,8	55,8	96,0	79,1	119,3	102,3	142,6	125,6	
	11	66,6	47,9					68,4	49,7	91,7	73,0	114,9	96,3	138,2	119,5	
	12	72,7	52,3					64,0	43,7	87,3	66,9	110,6	90,2	133,8	113,5	
	ACSE0105	5	46,1	39,3	64,6	57,8	99,2	92,4								
		6	55,3	47,2	56,8	48,6	91,4	83,2	126,0	117,9						
		7	64,5	55,0	48,9	39,4	83,5	74,0	118,2	108,6	152,8	143,3				
		8	73,8	62,9	41,0	30,2	75,7	64,8	110,3	99,4	144,9	134,1	179,6	168,7		
9		83,0	70,7			67,8	55,6	102,4	90,2	137,1	124,8	171,7	159,5	206,4	194,1	
10		92,2	78,6			59,9	46,3	94,6	81,0	129,2	115,6	163,9	150,3	198,5	184,9	
11		101,4	86,5					86,7	71,8	121,4	106,4	156,0	141,0	190,6	175,7	
12		110,6	94,3					78,9	62,5	113,5	97,2	148,1	131,8	182,8	166,5	
ACSE0125		5	80,0	53,0	131,0	104,0	192,0	166,0								
		6	96,0	64,0	120,0	88,0	182,0	150,0	243,0	211,0						
		7	112,0	74,0	110,0	72,0	171,0	134,0	233,0	195,0	294,0	257,0				
		8	128,0	85,0	99,0	56,0	161,0	118,0	222,0	179,0	283,0	241,0	345,0	302,0		
	9	144,0	95,0			150,0	102,0	211,0	163,0	273,0	225,0	334,0	286,0	395,0	347,0	
	10	160,0	106,0			139,0	86,0	200,0	147,0	262,0	209,0	324,0	270,0	385,0	331,0	
	11	175,0	117,0					191,0	131,0	252,0	193,0	313,0	254,0	374,0	315,0	
	12	191,0	127,0					180,0	115,0	241,0	177,0	302,0	238,0	364,0	299,0	
	ACSE0140	5	139,0	93,0	184,0	138,0	277,0	230,0								
		6	167,0	111,0	165,0	110,0	258,0	203,0	351,0	295,0						
		7	195,0	130,0	147,0	82,0	240,0	175,0	332,0	267,0	424,0	360,0				
		8	222,0	148,0	129,0	55,0	221,0	147,0	313,0	239,0	406,0	332,0	498,0	424,0		
9		250,0	167,0			203,0	119,0	295,0	212,0	387,0	304,0	480,0	396,0	572,0	489,0	
10		278,0	185,0			184,0	91,0	276,0	184,0	369,0	276,0	461,0	368,0	554,0	461,0	
11		306,0	204,0					258,0	156,0	350,0	248,0	443,0	341,0	535,0	433,0	
12		334,0	222,0					239,0	128,0	332,0	220,0	424,0	313,0	516,0	405,0	
ACSE0160		5	211,0	143,0	279,0	211,0	420,0	352,0								
		6	253,0	172,0	251,0	169,0	391,0	310,0	532,0	450,0						
		7	295,0	200,0	222,0	127,0	363,0	268,0	504,0	408,0	644,0	549,0				
		8	338,0	229,0	193,0	85,0	334,0	225,0	475,0	366,0	616,0	507,0	756,0	648,0		
	9	380,0	257,0			306,0	183,0	446,0	324,0	587,0	465,0	728,0	605,0	869,0	746,0	
	10	422,0	286,0			277,0	141,0	418,0	282,0	559,0	422,0	699,0	563,0	840,0	704,0	
	11	464,0	315,0					389,0	239,0	530,0	380,0	671,0	521,0	811,0	662,0	
	12	507,0	343,0					361,0	197,0	501,0	338,0	642,0	479,0	783,0	619,0	
	ACSE0190	5	349,0	232,0	448,0	332,0	675,0	559,0								
		6	418,0	278,0	402,0	262,0	629,0	489,0	856,0	716,0						
		7	488,0	325,0	356,0	192,0	582,0	419,0	809,0	646,0	1036,0	873,0	1217,0	1030,0		
		8	558,0	371,0	309,0	123,0	536,0	350,0	763,0	576,0	990,0	803,0	1217,0	1030,0		
9		627,0	418,0			490,0	280,0	717,0	507,0	943,0	733,0	1170,0	960,0	1397,0	1187,0	
10		697,0	464,0			443,0	210,0	670,0	437,0	897,0	664,0	1124,0	891,0	1351,0	1117,0	
11		767,0	510,0					624,0	367,0	851,0	594,0	1077,0	821,0	1304,0	1048,0	
12		837,0	557,0					577,0	297,0	804,0	524,0	1031,0	751,0	1258,0	978,0	
ACSE0210		5	467,0	297,0	638,0	468,0	950,0	780,0								
		6	560,0	356,0	579,0	375,0	891,0	687,0	1202,0	998,0						
		7	654,0	416,0	519,0	282,0	831,0	593,0	1143,0	905,0	1455,0	1217,0				



CONFIGURACION DE LOS MUELLES / SPRING CONFIGURATION

La colocación correcta de los muelles (incluso número impar), es como sigue:
 The correct placement of the springs (even odd number), is as follows:

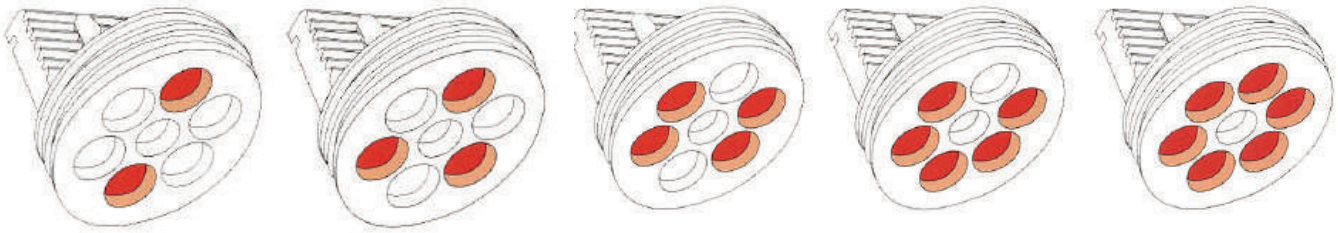

ESQUEMA DE FUNCIONAMIENTO

Posición de suministro estándar: NC (Normalmente Cerrado).
 Rotación estándar para abrir (pasar de 0° a 90°):
 - tanto en SE como en DE: rotación en sentido anti-horario, el par es ejercido por el aire.
 Rotación estándar para cerrar (pasar de 90° a 0°):
 - en DE: rotación en sentido horario, el par es ejercido por el aire.
 - en SE: rotación en sentido horario, el par es ejercido por los muelles.

OPERATING SCHEME

Standard supply position: NC (Normally Closed).
 Standard rotation to open (from 0° to 90°):
 - both, SR and DA: counter clockwise rotation (CCW), the torque is exerted by the air.
 Standard rotation to close (from 90° to 0°):
 - DA: clockwise rotation (CW), the torque is exerted by the air.
 - SE: clockwise rotation (CW), the torque is exerted by the springs.

Doble efecto, operación de apertura

Double acting, opening operation

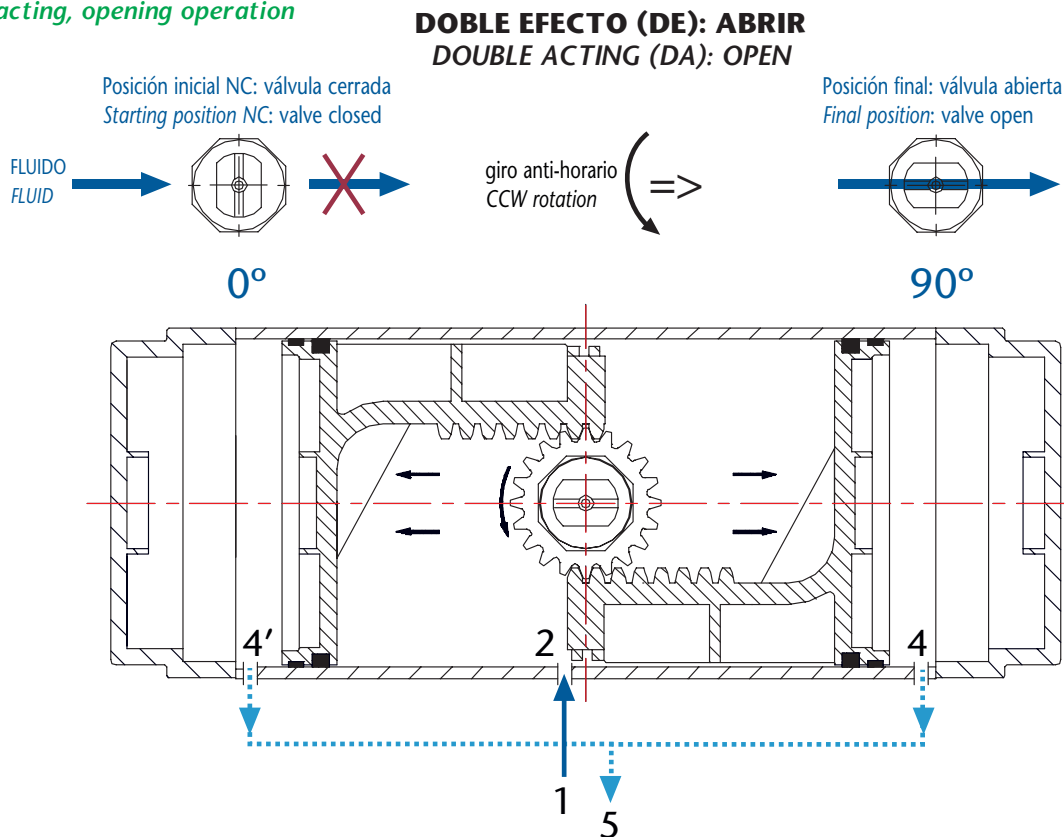

El aire a presión entra por el puerto 2 en la cámara central (vía 1 de electroválvula 5/2) desplazando los pistones en sentido anti-horario (CCW) hacia las cámaras laterales las cuales se comprimen saliendo su aire al exterior por los puertos laterales 4' y 4 conectados entre sí (vía 5 de la electroválvula 5/2). La cámara central queda presurizada y el piñón del actuador gira 90° (de 0° a 90°). El eje de la válvula ensamblado al actuador gira simultáneamente y ésta se abre.

The pressurized air enters through port 2 in the central chamber (via 1 of solenoid valve 5/2) moving the pistons in counter clockwise (CCW) direction towards the lateral chambers which are compressed and their air goes out through the side ports 4' and 4 connected to each other (via 5 of solenoid valve 5/2). The central chamber is pressurized and the actuator pinion rotates 90° (from 0° to 90°). The valve shaft assembled to the actuator rotates simultaneously and the valve is opened.

Rev.0-07.21
 5/11



Doble efecto, operación de cierre

Double acting, closing operation

DOBLE EFECTO (DE): CERRAR

DOUBLE ACTING (DA): CLOSE

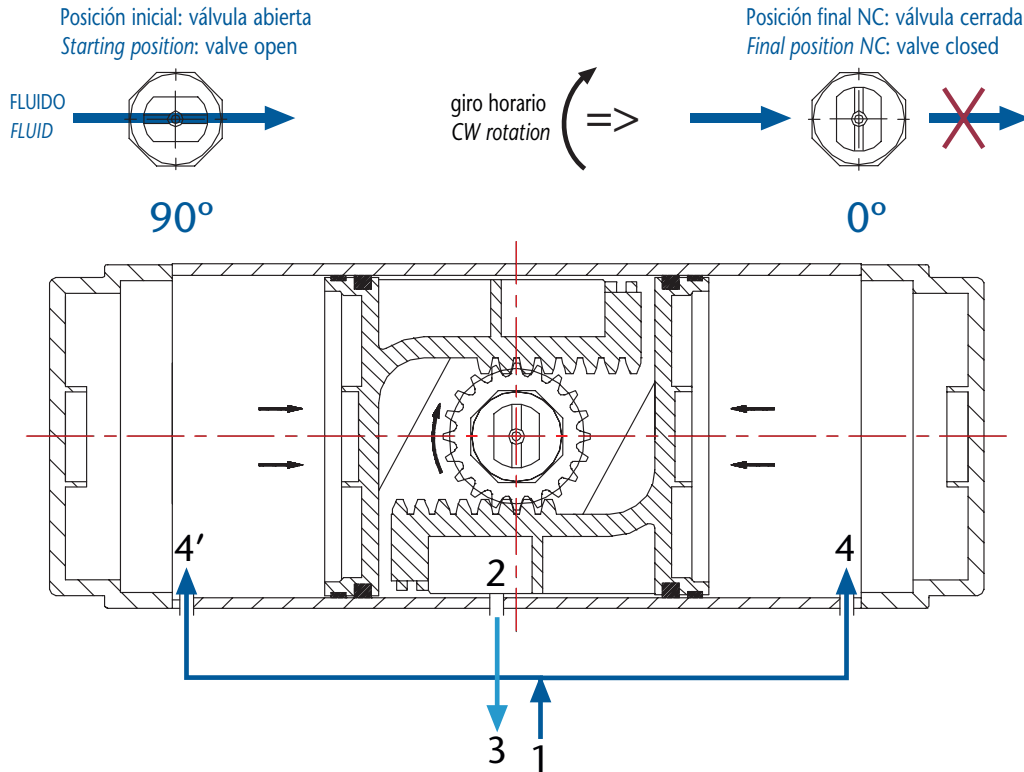

El aire a presión entra por los puertos 4' y 4 (vía 1 de electroválvula 5/2) conectados entre sí hacia las cámaras laterales desplazando los pistones en sentido horario (CW) hacia la cámara central la cual se despresuriza expulsando su aire por el puerto 2 (vía 3 de la electroválvula 5/2) y haciendo girar el piñón del actuador 90° (de 90° a 0°). El eje de la válvula ensamblada al actuador gira simultáneamente y ésta vuelve a su posición inicial cerrándose.

The pressurized air enters through ports 4' and 4 (via 1 of solenoid valve 5/2) connected to each other towards the side chambers moving the pistons in clockwise (CW) direction towards the central chamber which is depressurized by expelling its air through port 2 (via 3 of the 5/2 solenoid valve) and turning the actuator pinion 90° (from 90° to 0°). The valve shaft assembled to the actuator rotates simultaneously and it returns to its initial position by closing.

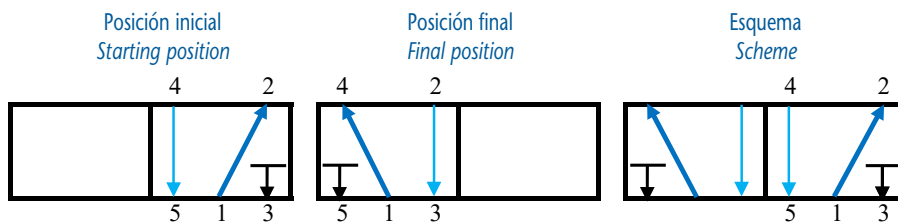

Nota : En caso de fallo o corte voluntario de aire, el actuador-válvula se queda permanentemente en la posición en la que esté en ese momento.
Note : In case of failure or voluntary air cut, the actuator-valve remains permanently in the position in which it is at that moment.

ACTUADORES NEUMATICOS DE SIMPLE Y DOBLE EFECTO

SINGLE RETURN AND DOUBLE ACTING PNEUMATIC ACTUATORS



Simple efecto, operación de apertura

Single acting, opening operation

SIMPLE EFECTO (SE): ABRIR

SINGLE RETURN (SR): OPEN

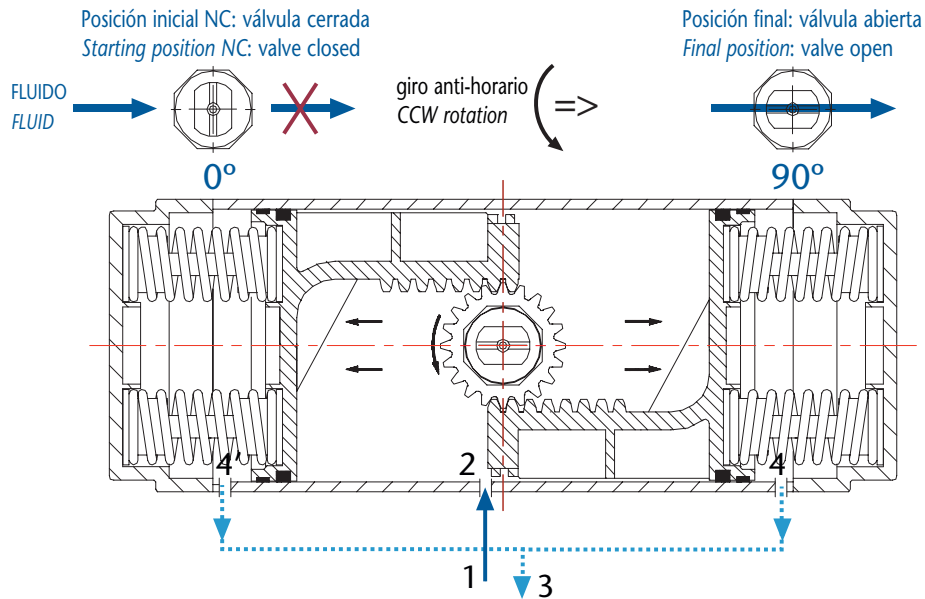

El aire a presión entra por el puerto 2 en la cámara central (vía 1 de electroválvula 3/2) desplazando los pistones en sentido anti-horario (CCW) hacia las cámaras laterales y comprimiendo así los muelles. La cámara central queda presurizada y el aire de las cámaras laterales sale al exterior por los puertos laterales 4' y 4 conectados entre sí (vía 3 de electroválvula 3/2) girando el piñon del actuador 90° (de 0° a 90°). El eje de la válvula ensamblada al actuador gira simultáneamente y ésta se abre. Si el actuador se alimenta permanentemente de aire a presión éste permanece en reposo en esa posición y la válvula está permanentemente abierta.

The pressurized air enters through port 2 in the central chamber (via 1 of solenoid valve 3/2) moving the pistons in counter clockwise direction (CCW) towards the side chambers and thus compressing the springs. The central chamber is pressurized and the air from the side chambers goes out through the lateral ports 4' and 4 connected to each other (via 3 of solenoid valve 3/2) turning the pinion of the actuator 90° (from 0° to 90°). The valve shaft assembled to the actuator rotates simultaneously and the valve open. If the actuator is permanently supplied with pressurized air, it remains at rest in that position and the valve is permanently open.

Simple efecto, operación de cierre

Single acting, closing operation

SIMPLE EFECTO (SE): CERRAR

SINGLE RETURN (SR): CLOSE

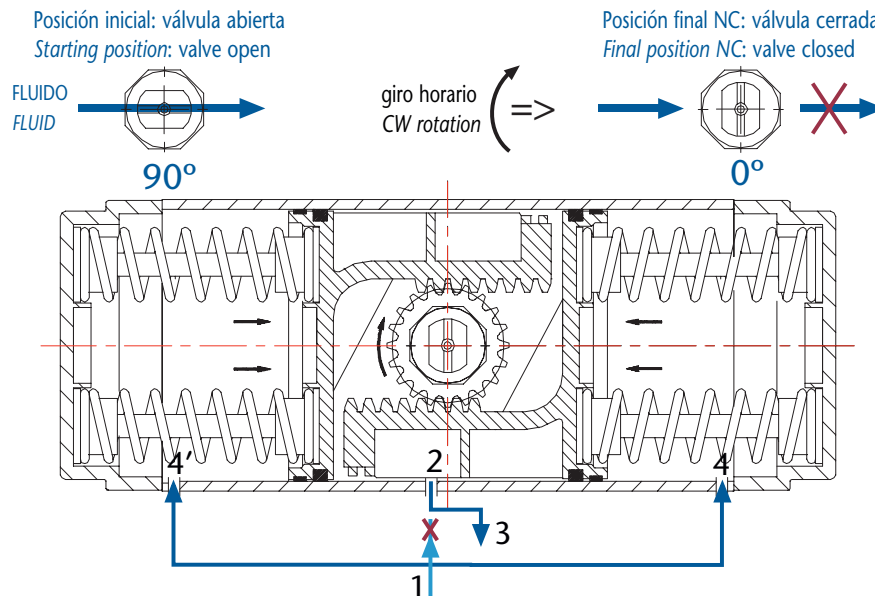

Una vez se anula la entrada de aire a presión al puerto 2 de la cámara central (vía 1 de electroválvula 3/2) ésta se descomprime expulsando el aire y provocando un efecto succión en las cámaras laterales y descomprimiendo los muelles cuya elongación provoca que los pistones se muevan en sentido horario (CW) haciendo que el piñon del actuador gire 90° (de 90° a 0°). El eje de la válvula ensamblada al actuador gira simultáneamente y ésta vuelve a su posición inicial (definida como de seguridad) cerrándose.

Once the inlet of pressurized air to port 2 of the central chamber (via 1 of solenoid valve 3/2) is cancelled, it is decompressed, expelling the air and causing a suction effect in the side chambers and decompressing the springs whose elongation causes the pistons to move in the clockwise (CW) direction making the actuator pinion rotate 90° (from 90° to 0°). The valve shaft assembled to the actuator rotates simultaneously and it returns to its initial closed position (defined as safety).

Rev.0-07.21
7/11



DIMENSIONES DE LOS ACTUADORES / ACTUATOR DIMENSIONS

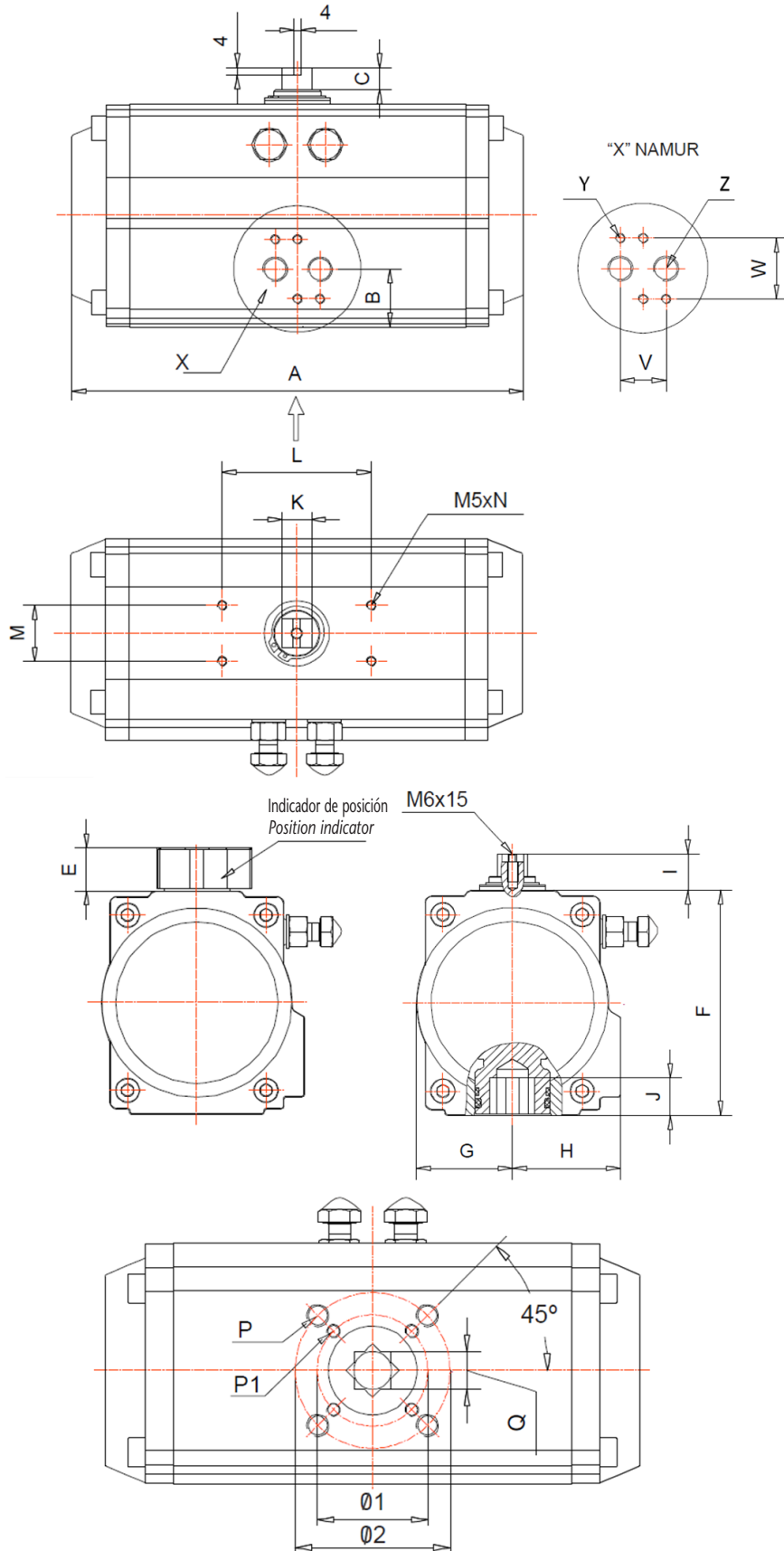

ACTUADORES NEUMATICOS DE SIMPLE Y DOBLE EFECTO

SINGLE RETURN AND DOUBLE ACTING PNEUMATIC ACTUATORS



DIMENSIONES DE LOS ACTUADORES - SIMPLE y DOBLE EFECTO (mm)

ACTUATORS DIMENSIONS - SINGLE RETURN and DOUBLE ACTING (mm)

Modelo Model	ACSE0052 ACDE0052	ACSE0063 ACDE0063	ACSE0075 ACDE0075	ACSE0083 ACDE0083	ACSE0092 ACDE0092	ACSE0105 ACDE0105	ACSE125 ACDE125	ACSE0140 ACDE0140	ACSE0160 ACDE0160	ACSE0190 ACDE0190	ACSE0210 ACDE0210	ACSE0240 ACDE0240	ACSE0270 ACDE0270	ACSE0300 ACDE0300
ISO 5211	F03-F05	F05-F07	F05-F07	F05-F07	F05-F07	F07-F10	F07-F10	F10-F12	F10-F12	F14	F14	F16	F16	F16
A	145,0	169,0	201,0	209,0	242,0	275,0	332,0	385,0	450,0	507,0	562,0	646,0	722,0	825,0
B	24,0	25,5	27,0	30,5	31,0	32,5	33,0	39,5	43,5	58,5	64,0	72,0	74,0	85,0
C	12,0	12,0	12,0	12,0	12,0	12,0	12,0	12,0	12,0	20,0	20,0	20,0	20,0	20,0
D	40,0	40,0	40,0	40,0	40,0	40,0	55,0	55,0	55,0	80,0	80,0	80,0	80,0	80,0
E	22,0	22,0	22,0	22,0	22,0	22,0	22,0	22,0	22,0	33,0	33,0	33,0	33,0	33,0
F	72,0	88,0	100,0	108,0	120,0	133,0	155,0	171,5	197,0	230,0	255,0	290,0	320,0	354,0
G	30,0	36,0	42,0	46,0	51,0	58,0	67,5	76,0	86,5	103,0	113,0	129,0	146,0	162,0
H	41,0	46,0	52,0	55,0	57,5	64,0	70,0	77,0	87,5	103,0	113,0	129,0	146,0	173,0
I	20,0	20,0	20,0	20,0	20,0	20,0	20,0	20,0	20,0	30,0	30,0	30,0	30,0	30,0
Jmin	13,0	16,0	20,0	20,0	20,0	25,0	25,0	30,0	30,0	40,0	40,0	50,0	50,0	50,0
K	12,0	12,0	12,0	16,0	16,0	16,0	22,0	22,0	22,0	32,0	32,0	32,0	32,0	32,0
L	80,0	80,0	80,0	80,0	80,0	80,0	80,0	80,0	80,0	130,0	130,0	130,0	130,0	130,0
M	30,0	30,0	30,0	30,0	30,0	30,0	30,0	30,0	30,0	30,0	30,0	30,0	30,0	30,0
N	8,0	8,0	8,0	8,0	8,0	8,0	8,0	8,0	8,0	8,0	8,0	8,0	8,0	8,0
ø1	36,0	50,0	50,0	50,0	50,0	70,0	70,0	102,0	102,0	----	----	----	----	----
ø2	50,0	70,0	70,0	70,0	70,0	102,0	102,0	125,0	125,0	140,0	140,0	165,0	165,0	165,0
P1	4-M5	4-M6	4-M6	4-M6	4-M6	4-M8	4-M8	4-M10	4-M10	----	----	----	----	----
P	4-M6	4-M8	4-M8	4-M8	4-M8	4-M10	4-M10	4-M12	4-M12	4-M16	4-M16	4-M20	4-M20	4-M20
Q	11,0	14,0	17,0	17,0	17,0	22,0	22,0	27,0	27,0	36,0	36,0	46,0	46,0	46,0
V	24,0	24,0	24,0	24,0	24,0	24,0	24,0	24,0	24,0	24,0	24,0	40,0	40,0	40,0
W	32,0	32,0	32,0	32,0	32,0	32,0	32,0	32,0	32,0	32,0	32,0	45,0	45,0	45,0
Y	M5x8	M5x8	M5x8	M5x8	M5x8	M5x8	M5x8	M5x8	M5x8	M5x8	M5x8	M6x10	M6x10	M6x10
Z	1/4"	1/4"	1/4"	1/4"	1/4"	1/4"	1/4"	1/4"	1/4"	1/4"	1/4"	3/8"	3/8"	1/2"



DIMENSIONES DE VALVULAS WAFER ACTUADAS / ACTUATED WAFER VALVES DIMENSIONS

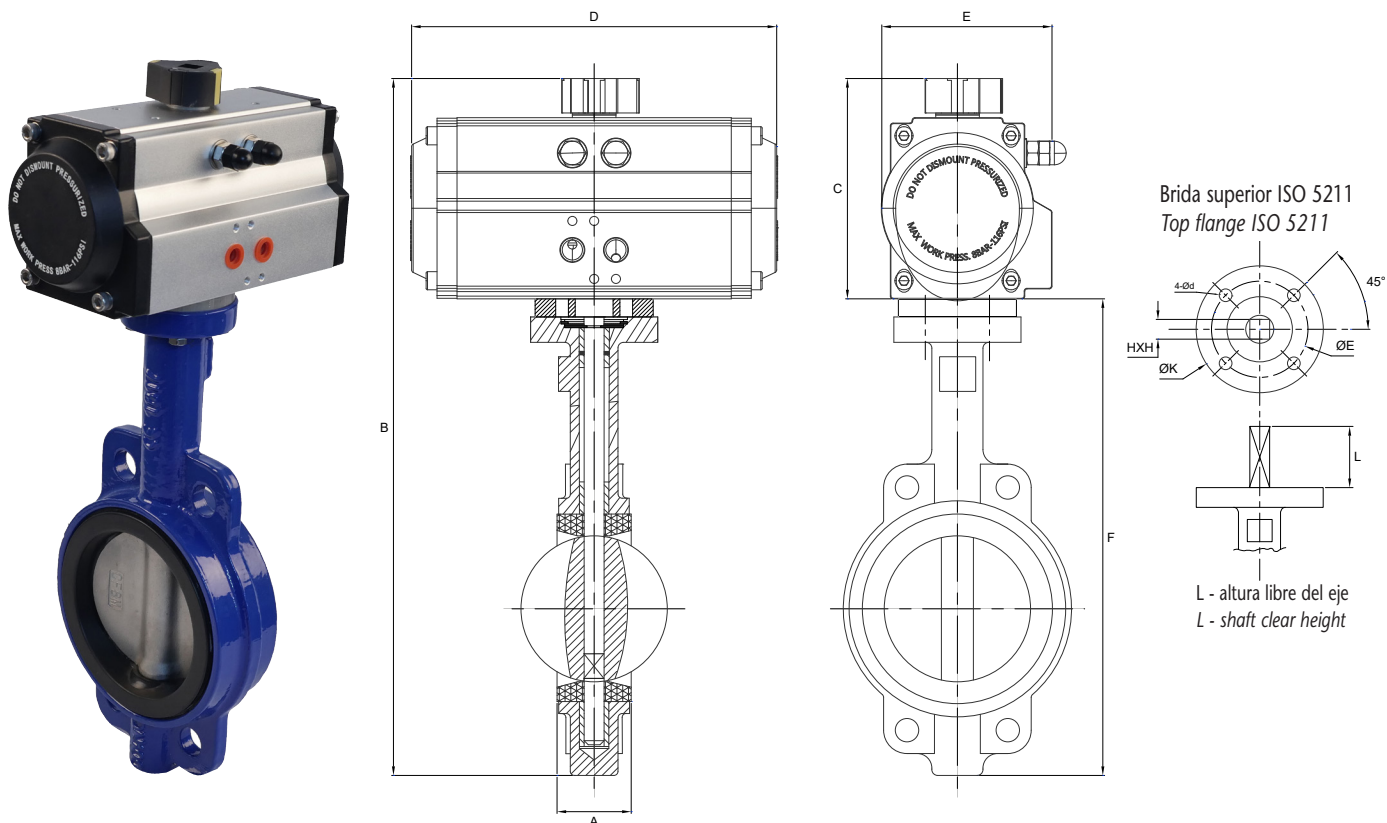

DIMENSIONES DE VALVULAS WAFER ACTUADAS - DIMENSIONS OF ACTUATED WAFER VALVES

DN	DIMENSIONES - DIMENSIONS (mm)													BRIDA / FLANGE - ISO 5211			
	A	B _{SE/SR}	B _{DE/DA}	C _{SE/SR}	C _{DE/DA}	D _{SE/SR}	D _{DE/DA}	E _{DE/DA}	E _{SE/SR}	F _{SE/SR}	F _{DE/DA}	L	H x H	Tipo de brida Flange Type	4 - Ød	ØK	ØE
	32	33	302	302	92	92	145	145	71	71	210	210	24	9 x 9	F05	4 - 7	70
40	33	327	327	92	92	145	145	71	71	235	235	24	9 x 9	F05	4 - 7	70	50
50	43	354	338	108	92	169	145	82	71	246	246	29	9 x 9	F05	4 - 7	70	50
65	46	394	366	120	92	201	145	94	71	274	274	29	9 x 9	F05	4 - 7	70	50
80	46	414	394	128	108	209	169	101	82	286	286	26	11 x 11	F05	4 - 7	70	50
100	52	464	444	140	120	242	201	109	94	324	324	26	11 x 11	F05	4 - 7	70	50
125	56	503	483	153	128	275	209	122	101	350	355	28	14 x 14	F07	4 - 9	90	70
150	56	550	520	175	140	332	242	138	109	375	380	32	14 x 14	F07	4 - 9	90	70
200	60	637	603	192	153	385	275	153	122	445	450	29	17 x 17	F07	4 - 9	90	70
250	68	723	681	217	175	450	332	175	138	506	506	38	22 x 22	F10	4 - 12	125	102
300	78	854	782	260	192	507	385	206	153	594	590	34	22 x 22	F10	4 - 12	125	102

Nota : Las medidas son orientativas y pueden cambiar sin previo aviso.
 Note : The measurements are indicative and may change without prior notice.



DIMENSIONES DE VALVULAS LUG ACTUADAS / ACTUATED LUG VALVES DIMENSIONS

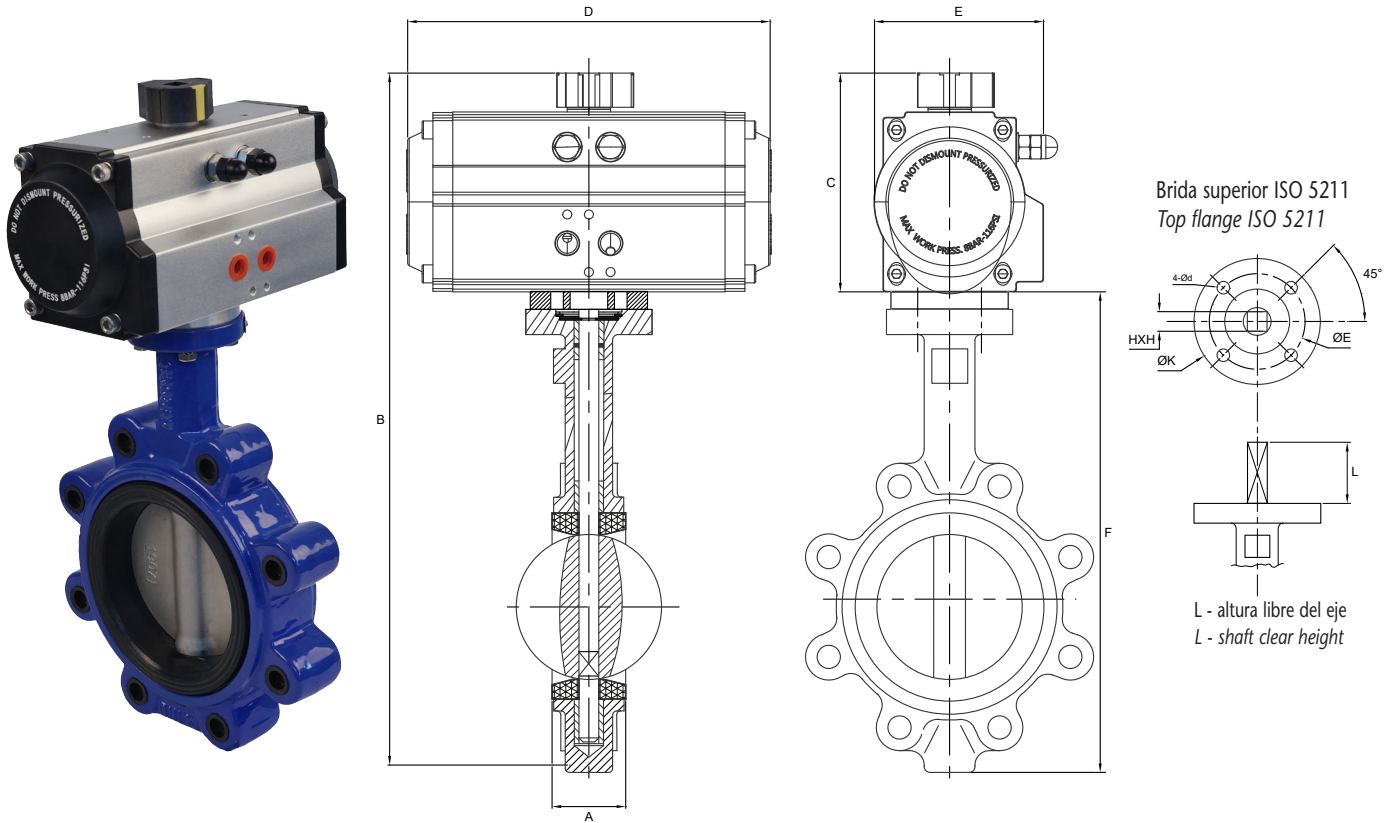

DIMENSIONES DE VALVULAS LUG ACTUADAS - DIMENSIONS OF ACTUATED LUG VALVES

DN	DIMENSIONES - DIMENSIONS (mm)													BRIDA / FLANGE - ISO 5211			
	A	B _{SE/SR}	B _{DE/DA}	C _{SE/SR}	C _{DE/DA}	D _{SE/SR}	D _{DE/DA}	E _{DE/DA}	E _{SE/SR}	F _{SE/SR}	F _{DE/DA}	L	H x H	Tipo de brida Flange Type	4 - Ød	ØK	ØE
	32	33	316	316	92	92	145	145	71	71	224	224	23	9x9	F05	4 - 7	70
40	33	316	316	92	92	145	145	71	71	224	224	23	9x9	F05	4 - 7	70	50
50	43	315	299	108	92	169	145	82	71	207	207	23	9x9	F05	4 - 7	70	50
65	46	345	317	120	92	201	145	94	71	225	225	23	9x9	F05	4 - 7	70	50
80	46	377	357	128	108	209	169	101	82	249	249	24	11x11	F05	4 - 7	70	50
100	52	413	393	140	120	242	201	109	94	273	273	24	11x11	F05	4 - 7	70	50
125	56	493	473	153	128	275	209	122	101	340	345	27	14x14	F07	4 - 9	90	70
150	56	550	520	175	140	332	242	138	109	375	380	27	14x14	F07	4 - 9	90	70
200	60	634	600	192	153	385	275	153	122	442	447	30	17x17	F07	4 - 9	90	70
250	68	728	686	217	175	450	332	175	138	511	511	31	22x22	F10	4 - 12	125	102
300	78	854	782	260	192	507	385	206	153	594	590	31	22x22	F10	4 - 12	125	102

Nota : Las medidas son orientativas y pueden cambiar sin previo aviso.
 Note : The measurements are indicative and may change without prior notice.

Nota : Debido al constante desarrollo de nuestros productos, los datos suministrados pueden ser alterados sin previo aviso.
 Note : Due to the continuous development of our products, specifications may be changed without notification at any time.

Rev.0-07.21
 11/11